

## 1. Safety instructions:

**Attention:**

**Laser radiation**, range approx. 5 to 10m

Never look into the laser beam and never point it at people, animals or highly reflective surfaces

Laser class 2 (EN60825-1: 1997)

Wavelength: 630 - 680nm Power: < 1mW

Power supply: 3 x 1.5V (LR44)

Disposal: Batteries are hazardous waste. Do not dispose of with household waste.

**Attention:**

**Neodymium magnets!** Included in target markers and line lasers

People with pacemakers should not use the device for safety reasons.

Keep your distance from electronic devices and wristwatches to avoid interference.

**Attention**

The product is not allowed to be used in potentially explosive areas.

- Avoid mechanical stress on the device
- Do not expose it to temperatures >50°C, strong vibrations, moisture or humidity.
- The device must not be modified or operated with a different power supply.

Failure to observe this may result in damage to the measuring device and invalidate the warranty. We accept no liability for consequential damage of any kind. If you have any questions, please contact us.

Before switching on the device, take preventive measures to ensure that people in the vicinity are not endangered.

## 2. Operating instructions:

The SIT LINE-LASER is placed on a flat surface of the two drive disks to be aligned with each other. In the case of magnetic materials, the device adheres by itself. For other materials, it must be held in place or attached in some other way, e.g. with double-sided adhesive tape.

The three target markers supplied are attached to a flat surface of the second disk as shown schematically below. These also adhere magnetically.

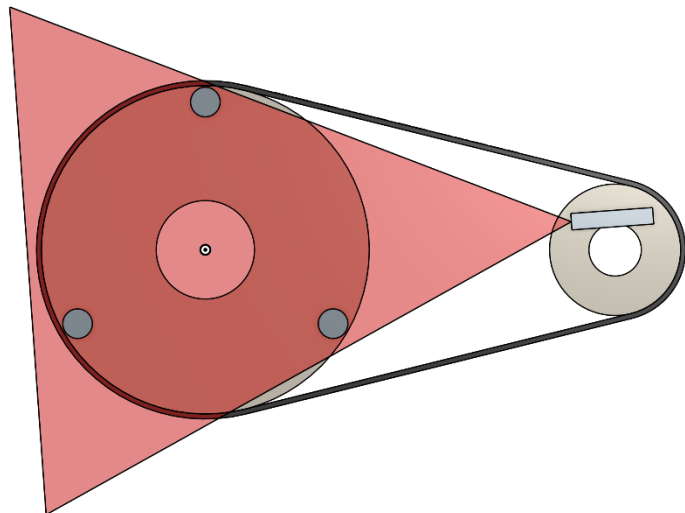

Figure 1- Side view of mounting situation, left the 3 target markers, right the line laser, laser field = red



Figure 2 - Installation situation top view, laser field = red

The target to be aligned is set correctly if the same point is hit on all three target marks. The lower edge of the area "0" means that both targets are at exactly the same height if both targets have the same width.

If one target is to be offset from the other, e.g. if one of the targets is wider, the magnet can be rotated around its own longitudinal axis. The edges of the surfaces rise or fall by one millimeter for every eighth rotation. The offset values for orientation can be read off the target markers for each quarter turn.

The alignment must be axial, horizontal and vertical.

The beam exit on the laser device is 5 mm above the base surface. This corresponds to the lower edge of the "0" area (arrow mark) on the target marker.

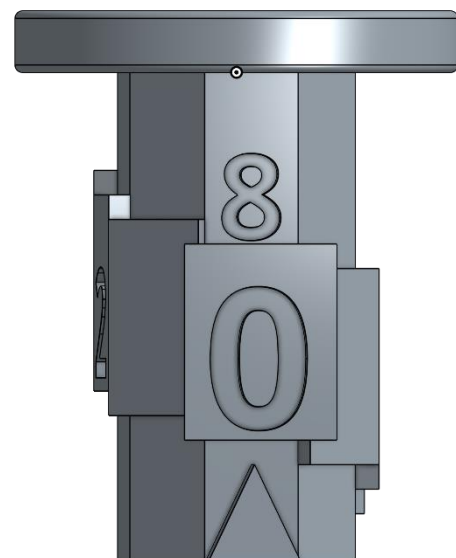

Figure 3- Target Marker, side view